

EXTRANEAL™

Icodextrin 7.5% Peritoneal Dialysis Solution

Blood glucose management with EXTRANEAL™ must be done with a glucose-specific method to avoid interference resulting in unrecognised hypoglycaemia. If non-specific glucose test methods glucose dehydrogenase pyrroloquinolinequinone (GDH-PQQ), Glucose-dye-oxidoreductase (GDO) or glucose dehydrogenase flavin-adenine dinucleotide (GDH-FAD) – based methods are used, loss of consciousness, neurological damage and death may occur (see WARNINGS AND PRECAUTIONS/Precautions).

DESCRIPTION

EXTRANEAL™ is a sterile peritoneal dialysis fluid containing icodextrin as the active ingredient at a concentration of 7.5% w/v in an electrolyte solution. It is presented in a flexible PVC bag and is sterile, non-pyrogenic and contains no bacteriostatic or antimicrobial agents or added buffers.

Each 1000mL of EXTRANEAL™ contains:

Icodextrin	75g
Sodium Chloride	5.4g
Sodium Lactate	4.5g
Calcium Chloride	257mg
Magnesium Chloride	51mg
Sodium Hydroxide	pH adjustment
Hydrochloric acid	pH adjustment
Water for injections	q.s.
Theoretical Osmolarity	284 (milliosmoles per litre)

Electrolyte Solution Content per 1000mL:

Sodium	133mmol
Calcium	1.75mmol
Magnesium	0.25mmol
Chloride	96mmol
Lactate	40mmol

Icodextrin is an $\alpha_{(1-4)}$ linked glucose polymer that contains 5% - 10% $\alpha_{(1-6)}$ links. It is produced by the hydrolysis of starch and fractionated by membrane separation technology to produce material with the desired molecular weight distribution (85% w/w within the molecular weight range 1,640 - 45,000).

The CAS Registration Number for icodextrin is 337376-15-5. Its chemical structure is shown below: -

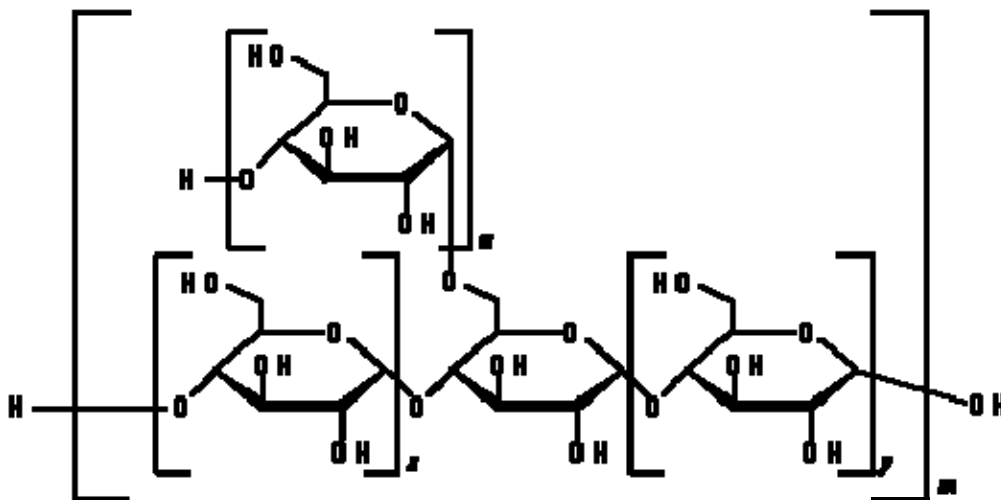

PHARMACOLOGY

Pharmacodynamic Properties

Icodextrin is a starch derived glucose polymer, which acts as an osmotic agent when administered intraperitoneally for continuous ambulatory peritoneal dialysis. A 7.5% solution is approximately iso-osmolar to serum but produces sustained ultrafiltration over a period up to 12 hours in Continuous Ambulatory Peritoneal Dialysis (CAPD). The volume of ultrafiltrate produced is comparable to that with 3.86% glucose when used in CAPD. Blood glucose and insulin levels remain unaffected.

Pharmacokinetic Properties

In a single-dose pharmacokinetic study using EXTRANEALTM (n = 13), a median of 40% (60g) of the instilled icodextrin was absorbed from the peritoneal solution during a 12-hour dwell. Plasma levels of icodextrin rose during the dwell and declined after the dwell was drained. Peak plasma levels of icodextrin plus its metabolites (median C_{peak} 2.2g/L) were observed at the end of the long dwell exchange (median T_{max} = 13 hours). Plasma levels return to baseline values within 7 days following cessation of icodextrin administration.

At steady-state, the mean plasma level of icodextrin plus its metabolites was about 5g/L. In multidose studies, steady-state levels of icodextrin were achieved within one week.

Icodextrin is metabolised by alpha-amylase into oligosaccharides with a lower degree of polymerisation (DP), including maltose (DP2), maltotriose (DP3), maltotetraose (DP4), and higher molecular weight species. In a single dose study, DP2, DP3 and DP4 showed a progressive rise in plasma concentrations with a profile similar to that for total icodextrin, with peak values reached by the end of the dwell and declining thereafter. Only very small increases in blood levels of larger polymers were observed. Steady-state plasma levels of icodextrin metabolites were achieved within one week and stable plasma levels were observed during long-term administration. Steady state plasma levels of 1.8mg/mL have been measured for oligomers of glucose units greater than 9 (G9) and there is a rise in serum maltose (G2) to 1.1mg/mL but there is no significant change in serum osmolality. The long term effects of raised plasma levels of maltose and glucose polymer are unknown.

Some degree of metabolism of icodextrin occurs intraperitoneally with a progressive rise in the concentration of the smaller polymers in the dialysate during the 12-hour dwell. These fragments are cleared by peritoneal dialysis.

Icodextrin undergoes renal elimination in direct proportion to the level of residual renal function. Diffusion of the smaller icodextrin metabolites from plasma into the peritoneal cavity is also possible after systematic absorption and metabolism of icodextrin.

Clinical Trials

EXTRANEAL™ has demonstrated efficacy, as a peritoneal dialysis solution in clinical trials of approximately 400 patients studied with end-stage renal disease (ESRD). In active-controlled trials of one to six months in duration, EXTRANEAL™ used once-daily for the long dwell in either continuous ambulatory peritoneal dialysis (CAPD) or automated peritoneal dialysis (APD) therapy resulted in higher net ultrafiltration compared with 1.5% and 2.5% dextrose solutions, and higher creatinine and urea nitrogen clearances when compared to 2.5% dextrose. Net ultrafiltration was similar to 4.25% dextrose. There is no information on how creatinine and urea nitrogen clearances on EXTRANEAL™ compared with 4.25% dextrose. Effects were generally similar in CAPD and APD. These studies were conducted in male and female patients > 18 years of age. Survival analysis was not included in these protocols. Ultrafiltration (UF) was the primary efficacy endpoint for all three of the pivotal studies. The studies only evaluated the effects of EXTRANEAL™ on ultrafiltration for the long dwell; the effects on 24 hour ultrafiltration are unknown.

Clinical Efficacy Studies				
Study Description		Study Results		
RD-97-CA-130 Double-blind, comparing efficacy (UF)* and safety of 7.5% icodextrin (N = 90) with 2.5% dextrose (N = 85) for the overnight (8 - 15 hour) dwell in CAPD patients for 4 weeks.	The icodextrin group had a statistically significant greater net UF for the long dwell compared to dextrose (p = 0.001).			
	Ultrafiltration Volumes			
	Baseline		Treatment (week 4)	
	Ico	control	Ico	control
	261	328	605	379
	Creatinine and urea clearances were higher with icodextrin than 2.5% dextrose (p < 0.001).			
ML/IB/001 Open label study comparing the efficacy (UF) and safety of 7.5% icodextrin (N = 106) with that of dextrose (N = 103) for the long overnight dwell (8 - 12 hours) in CAPD patients for 6 months. *Patients Baseline UF was the UF measured with the solution (1.5% or 2.5%/4.25%) that they were using during the 2-week interval prior to being assigned to icodextrin or control (i.e. continue with their usual solution either 1.5% or 2.5%/4.25%).	Greater UF was seen in the icodextrin group compared to the 1.5% dextrose group (p = 0.0002). No difference was found in the icodextrin group compared to the high (2.5%/4.25%) dextrose group in an 8 and 12 hour-long dwell.			
	<i>Ultrafiltration Volume 8h dwell</i>			
	Baseline*		Week 20	
	Ico	1.5%	Ico	1.5%
	61	76	517	153
	<i>Ultrafiltration Volume 8h dwell</i>			
	Baseline		Week 20	
	Ico	2.5/4.25%	Ico	2.5/4.25%
	711	614	462	465
	<i>Ultrafiltration Volume 12h dwell</i>			
	Baseline		Week 21	
	Ico	1.5%	Ico	1.5%
	61	76	561	102
	<i>Ultrafiltration Volume 12h dwell</i>			
	Baseline		Week 21	
Ico	2.5/4.25%	Ico	2.5/4.25%	
711	614	553	414	

Clinical Efficacy Studies															
Study Description		Study Results													
Pro-Renal-Reg-035 Open-label, randomised, parallel group, active-controlled study to compare the efficacy (UF)* and safety of EXTRANEAL™ (7.5% icodextrin (N = 20) with that of 2.5% dextrose (N = 19) for the long daytime dwell (12 - 16 hours) in APD patients for 4 months.		Icodextrin produced greater UF compared to baseline (p = 0.001) and compared with dextrose (p = 0.001).													
		<i>Ultrafiltration Volume</i>													
		<table border="1"> <thead> <tr> <th colspan="2">Baseline</th> <th colspan="2">Week 12</th> </tr> <tr> <th>Ico</th> <th>control</th> <th>Ico</th> <th>control</th> </tr> </thead> <tbody> <tr> <td>-175</td> <td>-135</td> <td>206</td> <td>-166</td> </tr> </tbody> </table>		Baseline		Week 12		Ico	control	Ico	control	-175	-135	206	-166
		Baseline		Week 12											
		Ico	control	Ico	control										
-175	-135	206	-166												
Creatinine and urea clearances were higher in the icodextrin group compared to the dextrose group.															
*UF = Ultrafiltration															

INDICATIONS

EXTRANEAL™ (7.5% icodextrin) is indicated for use as an alternative osmotic agent in dialysis solutions for the long dwell exchange in patients treated with peritoneal dialysis.

CONTRAINDICATIONS

EXTRANEAL™ should not be used in patients with a known allergy to starch based polymers and/or icodextrin, in patients with maltose or isomaltose intolerance or patients with glycogen storage disease.

EXTRANEAL™ is also contraindicated in patients with:

- a history of abdominal surgery in the month preceding commencement of therapy or in patients with abdominal fistulae, tumours, open wounds, herniae or other conditions which compromise the integrity of the abdominal wall, abdominal surface or intra-abdominal cavity.
- pre-existing severe lactic acidosis.
- uncorrectable mechanical defects that prevent effective PD or increase the risk of infection.
- documented loss of peritoneal function or extensive adhesions that compromise peritoneal function.

WARNINGS AND PRECAUTIONS

Warnings

Dangerous Medicine-Device Interaction

Only use glucose-specific monitors and test strips to measure blood glucose levels in patients using EXTRANEAL™ (icodextrin) Peritoneal Dialysis solutions. Blood glucose monitoring devices using glucose dehydrogenase pyrroloquinolinequinone (GDH-PQQ), glucose-dye-oxidoreductase (GDO) or glucose dehydrogenase flavin-adenine dinucleotide (GDH-FAD) – based methods may not be used. The manufacturer(s) of the monitor and test strips should be contacted to determine if icodextrin or maltose causes interference or falsely elevated glucose results. Use of GDH-PQQ, GDO- or GDH-FAD-based glucose monitors and test strips has resulted in falsely elevated glucose readings (due to the presence of maltose, (see WARNINGS AND PRECAUTIONS/Precautions) and has led patients or health care providers to withhold treatment of hypoglycaemia or to administer insulin inappropriately. Both of these situations have resulted in unrecognised hypoglycaemia, which has led to loss of consciousness, coma, permanent neurological damage and death. Plasma levels of EXTRANEAL™ (icodextrin) and its metabolites return to baseline within approximately 14 days following cessation of EXTRANEAL™ (icodextrin) administration. Therefore falsely elevated glucose levels may be measured up to two weeks following cessation of EXTRANEAL™ (icodextrin) therapy when GDH-PQQ, GDO- or GDH-FAD-based blood glucose monitors and test strips are used.

Because GDH-PQQ, GDO- or GDH-FAD-based blood glucose monitors may be used in hospital settings, it is important that the health care providers of peritoneal dialysis patients using EXTRANEAL™ (icodextrin) carefully review the product information of the blood glucose testing system, including that of test strips, to determine if the system is appropriate for use with EXTRANEAL™ (icodextrin).

To avoid improper insulin administration, educate all patients on EXTRANEAL™ therapy to alert health care providers of this interaction whenever they are admitted to the hospital.

The manufacturer(s) of the monitor and test strips should be contacted to determine if icodextrin or maltose causes interference or falsely elevated glucose.

Encapsulating peritoneal sclerosis (EPS) is considered to be a known, rare complication of peritoneal dialysis therapy. EPS has been reported in patients using peritoneal dialysis solutions including EXTRANEAL™. Infrequent but fatal outcomes have been reported.

If peritonitis occurs, the choice and dosage of antibiotics should be based upon the results of identification and sensitivity studies of the isolated organism(s) when possible. Prior to identification of the involved organism(s), broad-spectrum antibiotics may be indicated.

Rarely, serious hypersensitivity reactions to EXTRANEAL™ have been reported such as toxic epidermal necrolysis, angioedema, serum sickness, erythema multiforme and vasculitis. If a serious reaction is suspected, discontinue EXTRANEAL™ and institute appropriate treatment as clinically indicated.

Patients with severe lactic acidosis should not be treated with lactate-based peritoneal dialysis solutions (see CONTRAINDICATIONS). It is recommended that patients with conditions known to increase the risk of lactic acidosis [e.g., acute renal failure, inborn errors of metabolism, treatment with medicines such as metformin and nucleoside/nucleotide reverse transcriptase inhibitors (NRTIs)] must be monitored for occurrence of lactic acidosis before the start of treatment and during treatment with lactate-based peritoneal dialysis solutions.

When prescribing the solution to be used for an individual patient, consideration should be given to the potential interaction between the dialysis treatment and therapy directed at other existing illnesses. Serum potassium levels should be monitored carefully in patients treated with cardiac glycosides. For example, rapid potassium removal may create arrhythmias in cardiac patients using digitalis or similar medicines; digitalis toxicity may be masked by hyperkalaemia, hypermagnesaemia, or hypocalcaemia. Correction of electrolytes by dialysis may precipitate signs and symptoms of digitalis excess. Conversely, toxicity may occur at suboptimal dosages of digitalis if potassium is low or calcium high.

Precautions

Use with caution in the following circumstances

EXTRANEAL™ associated skin reactions, including rash and pruritus, are generally mild or moderate in severity. Occasionally, these rashes have been associated with exfoliation. In the event of this occurring, and depending on the severity, EXTRANEAL™ should be withdrawn at least temporarily.

Peritoneal dialysis should be done with caution in patients with: 1) abdominal conditions, including disruption of the peritoneal membrane and diaphragm by surgery, from congenital anomalies or trauma until healing is complete, abdominal tumors, abdominal wall infection, herniae, faecal fistula, colostomy or ileostomy, frequent episodes of diverticulitis, inflammatory or ischaemic bowel disease, large polycystic kidneys, or other conditions that compromise the integrity of the abdominal wall, abdominal surface, or intra-abdominal cavity; and 2) other conditions including recent aortic graft replacement and severe pulmonary disease.

As with other peritoneal dialysis fluids, EXTRANEAL™ should be used with caution, after careful evaluation of its potential risks and benefits, in patients with conditions which preclude normal nutrition, with impaired respiratory function or potassium deficiency.

Patients should be carefully monitored to avoid over and under hydration. An accurate fluid balance record should be kept and the patient's body weight monitored.

Over infusion of an EXTRANEAL™ volume into the peritoneal cavity may be characterized by abdominal distension, feeling of fullness and/or shortness of breath.

Treatment of EXTRANEAL™ over infusion is to release the EXTRANEAL™ from the peritoneal cavity by drainage of the EXTRANEAL™ volume contained within the peritoneal cavity.

Blood chemistry, haematology and plasma Osmolality should be monitored at regular intervals.

Protein, amino acids, water soluble vitamins and other medicines may be lost during peritoneal dialysis and may require replacement.

In patients with hypercalcaemia, particularly in those on low-calcium peritoneal dialysis solutions, consideration should be given to the fact that EXTRANEAL™ is not provided in a low-calcium electrolyte solution.

- Potassium is omitted from EXTRANEAL™ solutions due to the risk of hyperkalaemia.
- In situations in which there is a normal serum potassium level or hypokalaemia, the addition of potassium chloride (up to a concentration of 4mEq/L) may be indicated to prevent severe hypokalaemia and should be made after careful evaluation of serum and total body potassium, only under the direction of a physician.

Fluid, haematology, blood chemistry, and electrolyte concentrations should be monitored periodically, including magnesium and bicarbonate. If serum magnesium levels are low, oral magnesium supplements or peritoneal dialysis solutions containing higher magnesium concentrations may be used.

Decreases in serum sodium and chloride have been observed in patients using EXTRANEAL™.

Solutions that are discoloured, cloudy, contain particulate matter, or show evidence of leakage should not be used.

The drained fluid should be inspected for the presence of fibrin or cloudiness, which may indicate the presence of peritonitis.

In diabetic patients, blood glucose levels should be regularly monitored, and the dosage of insulin or other treatment for hyperglycaemia should be adjusted following initiation of treatment with EXTRANEAL™.

Blood glucose measurement must be done with a glucose specific method to prevent maltose interference. Glucose dehydrogenase-based methods or Glucose-dye-oxidoreductase based methods should not be used.

It is recommended that reference is made to the relevant section of the glucose test kit product leaflet to ascertain that interference while using icodextrin-based dialysis therapy is not described (see WARNINGS AND PRECAUTIONS/Effects on Laboratory Tests).

Aseptic technique should be employed throughout the peritoneal dialysis procedure. If peritonitis occurs, the choice and dosage of antibiotics should be based upon the results of culture and sensitivity of the isolated organisms. Prior to identification of involved organisms, broad-spectrum antibiotics may be indicated.

To reduce discomfort on administration, the solution may be warmed in the over pouch to a temperature of 37°C prior to use. This should be done using dry heat, ideally within a warming cabinet. The bags should not be immersed in water nor should they be microwaved in order to warm due to the potential for patient injury or discomfort.

Treatment should be initiated and monitored under the supervision of a physician knowledgeable in the management of patients with renal failure.

Pregnancy should be excluded prior to therapy with EXTRANEAL™. A reliable method of contraception should be used by women of reproductive age, should they require long term treatment with EXTRANEAL™.

EXTRANEAL™ is intended for intraperitoneal administration only.

Not for intravenous injection.

Safety and effectiveness in paediatric patients have not been established.

Check the following before use

EXTRANEAL™ is not recommended during pregnancy or lactation, in children or in patients with acute renal failure.

This therapy is not recommended in patients with known allergy to starch based polymers or an icodextrin intolerance.

EXTRANEAL™ should not be used if there is a history of abdominal surgery in the month preceding commencement of therapy or if the patient is suffering from any of the following conditions affecting their abdomen: tumours, open wounds or herniae.

EXTRANEAL™ should not be used when acute renal failure has been diagnosed.

Carcinogenicity, Mutagenicity and Impairment of Fertility

Long term carcinogenicity studies of icodextrin have not been done. Icodextrin was not mutagenic in a bacterial gene mutation assay, and was not clastogenic in V79 Chinese hamster

lung cells *in vitro* or in mouse bone marrow cells *in vivo*. Potential effects on male and female fertility are unknown.

Use in Pregnancy, Category B2

The potential effects of EXTRANEAL™ on reproduction have not been adequately studied in animals. There is insufficient experience with the use of dialysis fluids in pregnant women.

Women of childbearing potential should be treated with EXTRANEAL™ only when adequate contraceptive precautions have been taken.

Physicians should carefully consider the potential risks and benefits for each specific patient before prescribing EXTRANEAL™.

Use in Lactation

There are no available data from animal studies on the effects of icodextrin administered during lactation. It is not known whether icodextrin and/or its metabolites are excreted into human milk. Because many medicines are excreted into human milk and because of the potential of adverse effects on the infants, EXTRANEAL™ should not be used in breastfeeding women.

Interactions with Other Medicines

None known - however, the blood concentrations of dialyzable medicines may be reduced by dialysis.

Corrective therapy should be instituted if necessary. In patients using cardiac glycosides, plasma levels of potassium and calcium must be carefully checked. In the event of abnormal levels, appropriate actions should be taken.

Antibiotics

No formal clinical drug interaction studies with antibiotics were conducted. *In vitro* compatibility studies with EXTRANEAL™ and the following antibiotics have demonstrated no effects with regard to minimum inhibitory concentration (MIC): vancomycin, cefazolin, ampicillin, ampicillin/ flucoxacillan, ceftazidime, gentamicin and amphotericin. However, aminoglycosides should not be mixed with penicillins due to chemical incompatibility.

Effects on Laboratory Tests

The safety and efficacy of EXTRANEAL™ was established via laboratory tests conducted on a patient study of over 200 individuals. A study of the results show that icodextrin use produced a greater ultrafiltration volume compared to weak 1.36% glucose and was as effective as the stronger (3.86%) glucose. The mean overnight ultrafiltration was 3.5 times greater than 1.36%

glucose at 8 hours and 5.5 times greater at 12 hours. No significant difference was observed at 8 or 12 hours comparing icodextrin to 3.86% glucose.

Extending the dwell time from 8 to 12 hours tended to reduce net ultrafiltration with glucose 1.36% but increase it with icodextrin. In addition 9 - 41% of patients on glucose (1.36 and 3.86%) experienced reabsorption of peritoneal dialysis fluid.

A subgroup analysis of diabetic patients showed that overall diabetic control and insulin requirements were not different in the icodextrin and glucose groups.

An increase in volume of ultrafiltrate after an 8 hour overnight dwell was seen in all patients when going from 1.36% glucose to icodextrin.

Decreases in serum sodium and chloride have been observed in patients using EXTRANEAL™. The mean change in serum sodium from baseline to the last study visit was -2.8mmol/L for patients on EXTRANEAL™ and -0.3mmol/L for patients on control solution. Four EXTRANEAL™ patients and two control patients developed serum sodium < 125mmol/L. The mean change in serum chloride from baseline to last study visit was -2.0mmol/L for EXTRANEAL™ patients and +0.6mmol/L for control patients. The declines in serum sodium and chloride may be related to dilution resulting from the presence of icodextrin metabolites in plasma. Although these decreases have been small and clinically unimportant, monitoring of the patients' serum electrolyte levels as part of routine blood chemistry testing is recommended.

An increase in mean serum alkaline phosphatase has been observed in clinical studies of ESRD patients receiving EXTRANEAL™. No associated increases in liver function tests were observed. Serum alkaline phosphatase levels did not show evidence of progressive increase over a 12-month study period. Levels returned to normal approximately two weeks after discontinuation of EXTRANEAL™.

There were individual cases where increased alkaline phosphatase was associated with elevated AST (SGOT), but neither elevation was considered causally related to treatment.

An apparent decrease in serum amylase activity has been observed in patients using EXTRANEAL™.

Blood glucose measurement must be done with a glucose-specific method to prevent maltose interference with test results. Since falsely elevated glucose levels have been observed with blood glucose monitoring devices and test strips that use glucose dehydrogenase pyrroloquinolinequinone (GDH PQQ) - based methods or Glucose-dye-oxidoreductase (GDO) - based methods, GDH PQQ-based methods should not be used to measure glucose levels in patients administered EXTRANEAL™. Also, the use of some glucose monitors and test strips using glucose dehydrogenase flavin-adenine dinucleotide (GDH-FAD) methodology has resulted in falsely elevated glucose readings due to the presence of maltose (see WARNINGS AND PRECAUTIONS/Precautions).

Ability to Drive and Use Machinery

Patients on peritoneal dialysis may experience undesirable effects, which could affect the ability to drive or use machines.

ADVERSE REACTIONS

Blood glucose management with EXTRANEAL™ must be done with a glucose-specific method to avoid interference resulting in unrecognised hypoglycaemia. If non-specific glucose test methods (GDH PQQ and Glucose-dye-oxidoreductase based methods) are used, loss of consciousness, neurological damage and death may occur. This is the result of falsely high blood glucose readings due to the interaction between icodextrin and its by-products and glucometers that use pyrroloquinolinequinone (GDH PQQ) or Glucose-dye-oxidoreductase based methods for measuring blood glucose.

A listing of adverse events reported in clinical studies, regardless of causality, occurring in $\geq 5\%$ of patients and more common on EXTRANEAL™ is presented in Table 1.

	EXTRANEAL™ N = 493	Control N = 347
Peritonitis	26%	25%
Upper respiratory infection	15%	13%
Hypertension	13%	8%
Rash	10%	5%
Headache	9%	7%
Abdominal Pain	8%	6%
Flu Syndrome	7%	6%
Nausea	7%	5%
Cough increase	7%	4%
Oedema	6%	5%
Accidental Injury	6%	4%
Chest Pain	5%	4%
Dyspepsia	5%	4%
Hyperglycaemia	5%	4%

Adverse reactions reported with an incidence of > 5% and at least as common on dextrose control included: pain, asthenia, exit site infection, infection, back pain, hypotension, diarrhoea, vomiting, nausea/vomiting, anaemia, peripheral oedema, hypokalemia, hyperphosphataemia, hypoproteinaemia, hypervolaemia, arthralgia, dizziness, dyspnoea, skin disorder, pruritus.

Adverse reactions on EXTRANEAL™ also include: anorexia/loss of appetite, blood volume decreased, constipation, muscle cramps, dehydration, disequilibrium syndrome, hypovolaemia, serum osmolality increased, ultrafiltration increased, urine volume decreased, weight increased and weight decreased.

Additional adverse events occurring at an incidence of < 5% and that may or may not have been related to EXTRANEAL™ include: pain on infusion, abdominal enlargement, cloudy effluent, bloody effluent, ultrafiltration decrease, postural hypotension, heart failure, hyponatraemia, hypochloroemia, hypercalcaemia, hypoglycaemia, alkaline phosphatase increase, SGPT increase, SGOT increase, cramping, confusion, lung oedema, facial oedema, exfoliative dermatitis, eczema, vesicobullous rash, maculopapular rash, erythema multiforme, serum amylase decrease, catheter blockage, disturbed vision, electrolyte imbalance, fatigue, fluid imbalance.

All reported events are included except those already listed in Table 1, those not plausibly associated with EXTRANEAL™, and those that were associated with the condition being treated or related to the dialysis procedure.

Other adverse events reported with EXTRANEAL™ include: furuncle, leucocytosis, eosinophilia, parathyroid disorder, hypomagnesaemia, anxiety, abnormal thinking, nervousness, hyperkinesia, paraesthesia, ageusia, tinnitus, tachycardia, hiccups, lung disorder, intestinal obstruction, gastrointestinal disorder, gastric ulcer, gastritis, dry mouth, flatulence, nail disorder, dry skin, skin discolouration, neck pain, renal pain, bone pain, muscle spasm, skin ulcer, psoriasis, dermatitis bullous, urticaria and myalgia.

Other undesirable effects of peritoneal dialysis related to the procedure and/or the solution. – The following undesirable effects are often reported spontaneously and in the literature:

Those which are related to the procedure include: peritonitis (septic or aseptic), with or without abdominal pain, cloudy effluent and sometimes fever; bleeding, catheter blockage, infection around the catheter (signs of inflammation: redness and secretion), hypervolaemia, hypovolaemia, hypertension, hypotension, dehydration, oedema, constipation, hernia of the abdominal cavity, ileus, loss of appetite, dyspepsia, nausea and vomiting, dizziness, fatigue, headache, shoulder pain, pruritus, muscle cramps, disturbed vision, dyspnoea/shortness of breath, fluid imbalance, pain, and abnormal laboratory test results.

Those which are generally related to peritoneal dialysis solutions are seen less frequently than those related to the procedure and include, electrolyte disturbances (e.g. hypokalaemia, hypocalcaemia and hypercalcaemia), fainting, muscle cramping, respiratory symptoms associated with shortness of breath and weakness, anorexia/loss of appetite, asthenia, catheter blockage, constipation, disturbed vision, disequilibrium syndrome, dyspnoea/shortness of breath,

oedema, cloudy effluent, exfoliative dermatitis, fatigue, fluid imbalance, hypertension, hypervolaemia, exit site infection, abdominal pain, peritonitis, aseptic peritonitis and rash.

In addition there have been common reports of skin reactions in patients treated with icodextrin, including rash and pruritis. Occasionally, these rashes have been associated with exfoliation. The incidence of rash considered to be related to treatment in pooled data from all clinical studies* was 5.5% for EXTRANEAL™ treated patients compared with 1.7% in patients treated with dextrose solutions.

Post marketing Surveillance

Post Marketing Surveillance data worldwide show that there have been serious hypoglycaemic reactions associated with the use of EXTRANEAL™ and non-glucose specific measuring devices. These reactions have resulted in death (2 cases to May, 2005) and hypoglycaemic coma with neurological sequelae (2 cases to May, 2005), and other hypoglycaemic events from which the patients recovered.

To avoid these events, a glucose specific blood glucose monitor must be used (see WARNINGS AND PRECAUTIONS).

In addition to the adverse reactions noted in clinical trials, the following adverse reactions have been reported in the post-marketing setting, listed by System Order Class (SOC), then by Preferred MedDRA term in order of severity.

INFECTIONS AND INFESTATIONS:

Fungal peritonitis, Peritonitis bacterial, Catheter site infection, Catheter related infection.

BLOOD AND LYMPHATIC SYSTEM DISORDERS:

Thrombocytopenia, Leucopenia.

IMMUNE SYSTEM DISORDERS:

Vasculitis, Serum sickness, Hypersensitivity.

METABOLISM AND NUTRITION DISORDERS:

Shock hypoglycaemia, Fluid overload, Fluid imbalance.

NERVOUS SYSTEM DISORDERS:

Hypoglycaemic coma, Burning sensation.

EYE DISORDERS:

Vision blurred.

RESPIRATORY, THORACIC, AND MEDIASTINAL DISORDERS:

Bronchospasm, Stidor.

GASTROINTESTINAL DISORDERS:

Sclerosing encapsulating peritonitis, Aseptic peritonitis*, Peritoneal cloudy effluent, Ileus, Ascites, Inguinal hernia, Abdominal discomfort.

SKIN AND SUBCUTANEOUS DISORDERS:

Toxic epidermal necrolysis, Erythema multiforme, Angioedema, Urticaria generalized, Toxic skin eruption, Swelling face, Periorbital oedema, Exfoliative rash, Skin exfoliation, Prurigo, Rash (including macular, papular, erythematous, exfoliative), Dermatitis (including allergic and contact), Drug eruption, Erythema, Onychomadesis, Skin chapped, Blister.

MUSCULOSKELETAL, CONNECTIVE TISSUE DISORDERS:

Arthralgia, Back pain, Musculoskeletal pain.

REPRODUCTIVE SYSTEM AND BREAST DISORDERS:

Penal oedema, Scrotal oedema.

GENERAL DISORDERS AND ADMINISTRATIVE SITE CONDITIONS:

Discomfort, Pyrexia, Chills, Malaise, Medicine effect decreased, Medicine ineffective, Catheter site erythema, Catheter site inflammation, Infusion related reaction (including Infusion site pain, Instillation site pain).

INJURY, POISONING AND PROCEDURAL COMPLICATIONS:

Device interaction.

*Lower level term

DOSAGE AND ADMINISTRATION

EXTRANEAL™ is recommended for use during the longest dwell period, that is in CAPD usually overnight and in Automated Peritoneal Dialysis (APD) for the long daytime dwell.

EXTRANEAL™ is intended for intraperitoneal administration only. Not for intravenous administration.

The mode of therapy, frequency of treatment, exchange volume, duration or dwell and length of dialysis should be initiated and supervised by the physician.

Adults

By intraperitoneal administration limited to a single exchange in each 24 hour-period, as part of a CAPD or APD regimen.

Elderly

As for adults.

Children

Not recommended for use in children (less than 18 years).

Aseptic technique should be observed throughout the procedure.

To reduce discomfort on administration, the solution may be warmed in the over pouch to a temperature of 37°C prior to use. This should be done using dry heat, ideally within a warming cabinet. The bags should not be immersed in water nor should they be microwaved in order to warm.

The volume to be instilled should be given over a period of approximately 10 to 20 minutes at a rate that the patients finds comfortable.

For adult patients of normal body size the instilled volume should not exceed 2.0L. If the instilled volume causes discomfort due to abdominal tension the instilled volume should be reduced.

The recommended dwell time is between 6 and 12 hours in CAPD and 14 -16 hours in APD.

Drainage of the fluid is by gravity at a rate comfortable for the patient. The drained fluid should be inspected for the presence of fibrin or cloudiness, which may indicate the presence of infection or aseptic peritonitis (see ADVERSE EVENTS).

OVERDOSAGE

No data is available on the effects of overdosage. However, continuous administration of more than one bag of EXTRANEAL™ in 24 hours would increase plasma levels of carbohydrate metabolites and maltose. The effects of such an increase are unknown but an increase in plasma osmolality may occur. Treatment could be managed by icodextrin-free peritoneal dialysis or haemodialysis.

PRESENTATION

Container

Standard single bag: Flexible PVC container in 1500mL, 2000mL, 2500mL and 3000mL volumes.

Twin Bag: Flexible PVC container in 1500mL, 2000mL,2500mL and 3000mL volumes. A drainage bag is attached.

Currently 2500 mL container available for standard single bag and twin bag only.

Shelf Life 2 years.

Store at or below 30°C.

Do not administer unless the solution is clear and the bag undamaged.

Single Use only.

Any unused portion of dialysate should be discarded.

MEDICINE CLASSIFICATION

General Sales Medicine.

NAME AND ADDRESS

New Zealand

Baxter Healthcare Ltd
PO Box 14 062
Panmure
Auckland 1741

Australia

Baxter Healthcare Pty Ltd
1 Baxter Drive
Toongabbie, NSW 2146

DATE OF PREPARATION

1 August 2011

Baxter and EXTRANEAL are registered trademarks of Baxter International Inc.

Based on Australian PI approved 17 October 2002, amended 30 June 2011.